

# Brightwash

Machines | Chemicals | Service

in partnership with

## Dominant<sup>®</sup>



## Hospitality

Cleaning, Sanitation  
and Hygiene Solutions  
for your hospitality facility



[dominant.com.au](http://dominant.com.au)

Health & Safety of staff and guests are of the highest importance, along with protection of your brand, cleaning product efficiency and effective cost per use.

Dominant have the ability to cover large-scale food service environments, or smaller fine-dining experiences including cleanliness of plates, glassware, cutlery, hygienic kitchen environments, and dining areas, to washroom, personal care and housekeeping products. The correct choice of product and dispensing systems can have a direct impact on the customer experience.

Protecting your hospitality relationships →



Catering



Restaurants & Cafés



Bars & Clubs



Hotels



Housekeeping

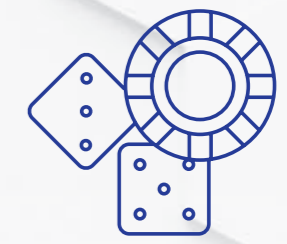

Casinos

## Dominant Quality Cleaning Products

Dominant have been developing and manufacturing high quality cleaning products for over 60 years, but we offer much more than that.



### Dispensing Equipment

We offer an extensive range of dispensing equipment including those with remote access to allow for ease of use, and accurate and safe dosing of product.

These include dosing pumps, electronic detergent feeders, mobile foaming units, hand wash dispensers and more.

### Food Safety

We have a range of products and services for safe food preparation and avoiding cross contamination.

- Non-perfumed, odourless products that will not taint foods
- Sanitisers for reducing bacteria levels
- Hygiene monitoring options to validate correct cleaning & sanitation procedures



### Technical Assistance

We have a team of qualified service technicians available for installation, and ongoing service and maintenance of dispensing equipment.



### Effective Cost per Use

Dominant manufacture many products in concentrated quantities. These can then be diluted with water into a reusable spray bottle.

Example: A 5L container of All Kleen Multi-Purpose Cleaner will give you 166 spray bottles

### Our Certifications

Dominant is committed to delivering high-quality products with consistent and reliable performance. That is why we have implemented and maintain management systems that exceed the requirements of International ISO standards. Allowing you to have confidence when using all Dominant products and services.



### Safety Focus

- Smaller and lighter product sizes for safe handling, eg 2L and 5L bottles
- The Dominant Protekta™ Cap – a completely sealed, closed-loop safety system that ensures safe delivery of product and protection from spills.
- Colour coded and labelled dispensing bottles and equipment
- Low allergen products

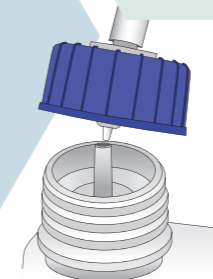

### Compliance Documentation

We understand food safety regulations and requirements and can provide supporting documentation including:

- Safety Data Sheets
- Chemical safety wall charts
- Product application charts
- Allergen statements



### Reporting & Auditing

Our team can offer:

- Detailed site audits to identify the requirements of a space, and provide risk assessments
- Hygiene Monitoring
- Dishwasher Reports
- Laundry Reports & Audits



### Education & Training

Onsite or online food safety and chemical handling training with modules and assessments to educate and evaluate competency of users.

- Chemical Awareness Training
- HACCP and Food Safety





# A full service product range for your facility →



**Front of House**

**Glaze Sheen**  
Premium quality glass and chrome cleaner ideal for windows, mirrors, stainless steel, chrome, glass and shiny surfaces.  
→ Ammonia-free

**Fresh Lemons**  
Clean, disinfects and deodorise with this multi-purpose product that can be used as a spray & wipe cleaner disinfectant or for mopping large areas.

**Mask**  
Cleaner deodoriser suitable for use in any area that requires odour control including rubbish bins, drains and waste management facilities.

**Pine Disinfectant**  
A multi-use disinfectant cleaner with pine oil that can be used on all washable surfaces as a spray & wipe or for mopping large areas.



**Bacban No Rinse Sanitiser**  
Bacban provides sanitation to hard surfaces without needing to rinse.

**Sanibac Sanitiser**  
Sanibac is a no rinse sanitiser for use in kitchens and food processing areas.

**LCC Sanitiser**  
Chlorinated sanitiser to clean, bleach and sanitise chopping boards.

**Food Sanitiser**  
Sanitiser for salad vegetables and for sanitising utensils after washing.

**Quicksan No Rinse Spray**  
Fast acting quaternary no rinse sanitiser ready-to-use surface spray. Contains alcohol for fast drying.



**Aquista Foaming**  
Odourless and fragrance free hand cleaner especially made for food preparation areas.

**Mia Kleer**  
Instant antibacterial alcohol hand gel for use without water. Contains 70% ethanol.

**Luna Hand Care**  
A premium range of hand and personal care products with a choice of fragrance and dispensing options.  
Fragrances include:  
→ French Pear  
→ Grapefruit & Lemon Verbena



**Glassmaster**  
Low foaming, free rinsing liquid detergent designed for glass washing machines.

**Result Dishwasher Powder**  
A non-caustic, chlorinated powder for use in domestic and commercial dishwashers.

**Hi-Tech Dishwashing Liquid**  
Concentrated product with excellent all round balance of performance and economy.

**Tornado Dishwashing Liquid**  
Concentrated chlorine based product with destaining and descaling properties.

**Typhoon Dishwashing Liquid**  
Premium quality, non-caustic automatic dishwashing detergent.

**Glisten**  
An effective and concentrated rinse aid for commercial dishwasher machines.



**Range Cleaner**  
Heavy duty caustic based cleaner for fast, effective removal, of baked on deposits on ovens and grills.

**Gorilla Griller, Oven and BBQ**  
Gorilla is a non-caustic oven cleaner that gives excellent removal of baked on deposits using a blend of detergents and natural solvents.

**Combi Foam Oven Cleaner**  
For removal of baked-on, and greasy soils from a range of hard surfaces. Ideal for use in liquid-fed Combi ovens, or deep-fryers.

**Combi Oven Cleaning Tablets**  
Ideal for use in all combi ovens that use powdered or tablet cleaners.

**Combi Clean Liquid**  
Specifically designed to clean a range of combi ovens.



**PX 22**  
An outstanding degreaser and all-purpose cleaning powder that removes a wide range of fats, oils and protein soils.

**Back of House**

**Breakaway Heavy Duty**  
Highly alkaline hard surface cleaner for greasy soils such as around deep fryers and chicken rotisseries. High foaming ability.

**Sanclean Cleaner/Sanitiser**  
A moderately alkaline quaternary ammonium based detergent sanitiser recommended for cleaning and sanitising in all areas. Cleans and kills bacteria in one easy step.

**Spray and Wipe Sanitiser**  
Convenient, ready-to-use product that cleans and sanitises hard surfaces in one easy action.

**Beer Line Cleaning**



**DUO Beerline Cleaner**  
Duo is a twin pack system containing caustic compounds in Part 1 and an oxygen bleach in Part 2. When mixed together they release oxygen to assist in cleaning and sanitation. Duo Part 1 also contains scale removing compounds to dissolve difficult to remove beerstone deposits.

**Saniglass Manual Detergent**  
Detergent sanitiser for cleaning and sanitising glasses washed manually.

**Washrooms**

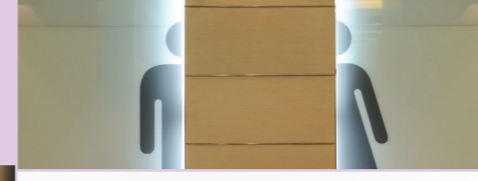

**Bathroom & Toilet Cleaner**  
An all-round bathroom and toilet cleaner that cleans, disinfects and descales all surfaces.

**Air Freshener Gels**  
Neutralise odours and replace them with a fresh fragrance.

**Miniburst Fragrances**  
Highly concentrated metered aerosol air fresheners with a choice of fragrance.

**Tenozid 8**  
Heavy duty bathroom and toilet cleaner containing a blend of phosphoric and organic acids as well as biodegradable detergents. Removes hard water scale, soap scum, body fat and other soils.

**Drain Cleaner**



**Bioflow Biological Cleaner**  
A biological treatment to control the build up of grease, fats oils and food solids in drains.

**Ready to Use Plant Powered Cleaning**

**PLANT POWERED**

Simplify the way you clean with our plant powered cleaning range. Lightweight, ready to use products with no dilution needed for convenient cleaning.





# Learn more about Dominant's solutions →



## Hand Hygiene

To assist in the prevention of cross contamination, Dominant hand care products are available in a variety of options including non-fragranced options for food service, mild products to prevent dermatitis in applications where frequent hand washing is required, and premium options for presentation and customer care at front of house.



## Food Safety

**Food Safety is critical to your business and we offer a range of products and training services to assist you in delivering safe food to your customers.**

- Food safety training
- Hand hygiene training
- Hand hygiene instruction posters

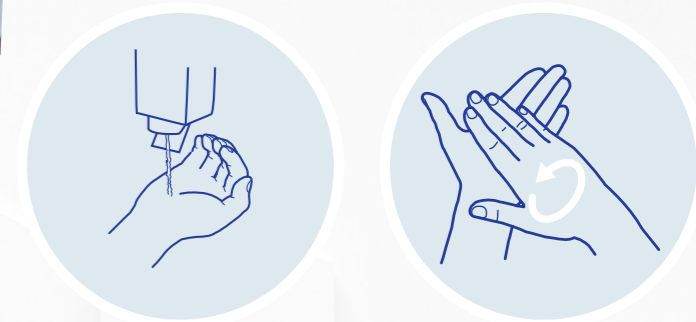

## Dominant Protekta® Cap

**The Protekta® Cap ensures safe delivery of the product without spillage, leaks or splashing and is colour-coded for ease of use.**

This system significantly reduces work health and safety issues associated with traditional systems. It restricts the end-user from being able to 'glug' chemical from the bottle, keeping product usage to a minimum.

- Completely sealed
- No spills
- Closed loop system

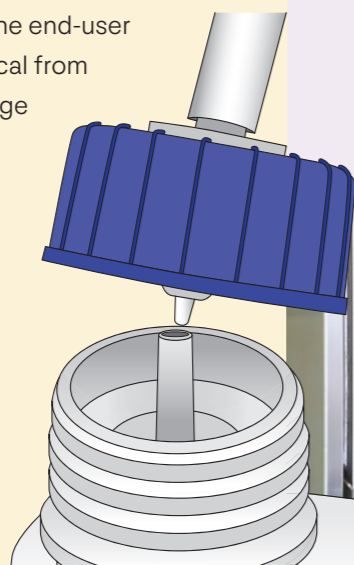

## Warewashing Experts

**Dominant specialise in a large range of product for warewashing machines.**

These products are distributed through a range of dispensing systems to suit your requirements. To ensure perfect results and accurate dosing, these systems are managed by our team of Account Managers and Service Technicians.



## Clean hands are safe hands →

### “How to” Signage

**Dominant provide step-by-step posters to educate the correct steps for hand washing.**

These serve as helpful reminders to encourage safe hand hygiene procedures at all times.

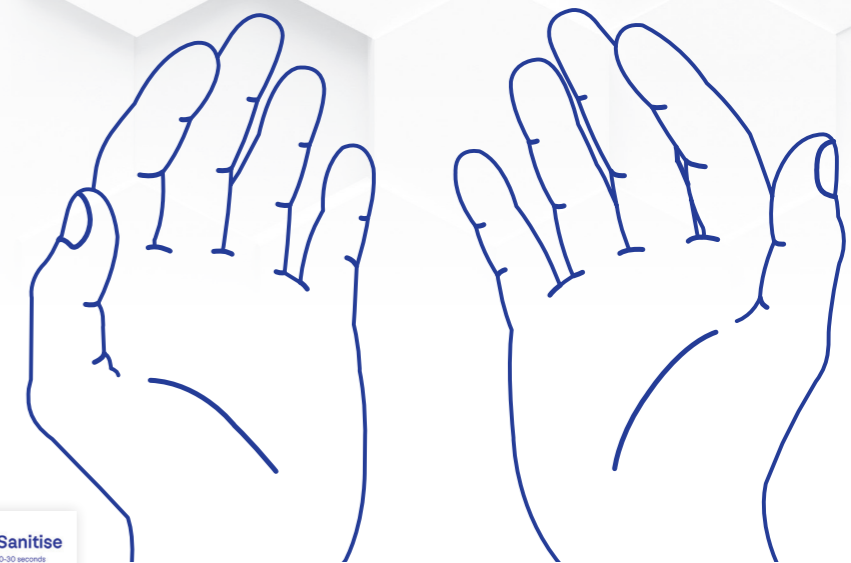





# Brightwash

Machines | Chemicals | Service

in partnership with

## Dominant<sup>®</sup>



Visit our website:

[www.btgau.com.au](http://www.btgau.com.au)



Send an email:

[sales@btgau.com.au](mailto:sales@btgau.com.au)



Give us a call:

**1300 367 177**

